

Part Number: PZQ64-42097

Kit Contents

Item #	Quantity Req'd.	Description
1	1	Tow Bar Welded Assembly
2	1	Tongue
3	1	LH Side Arm Assembly
4	1	RH Side Arm Assembly
5	2	Body Brace
6	1	LH Reinforcement Plate
7	1	RH Reinforcement Plate
8	1	LH Rear Bracket Assembly
9	1	RH Rear Bracket Assembly
10	1	Bumper Cover Trim & Glue
11	2	Shim Plate
12	1	Pin & Clip
13	21	Bolt, Hex M12 X 50 X 1.25
14	31	Washer, Flat M12
15	10	Nut, Hex M12 X 1.25
16	6	Bolt, Hex M8 X 35 X 1.25
17	14	Washer, Flat M8
18	8	Bolt, Hex M8 X 25
19	1	Washer, Thick M12
20	1	Hitch Plug
21	1	Warning Label

Additional Items Required For Installation

Item #	Quantity Req'd.	Description
1	1	3M Ultra Underbody Sealant (C0009-08302)
2		
3		

General Applicability

All RAV4 & Hybrid models except SE grade

Conflicts

SE models
Hands-free lift gate option

Recommended Sequence of Application

Item #	Accessory
1	Trailer Module & Power Wire Harnesses
2	Tow Hitch
3	Trailer 4-Flat Harness

*Mandatory

Vehicle Service Parts (may be required for reassembly)

Item #	Quantity Req'd.	Description
1		

Recommended Tools

Personal & Vehicle Protection	Notes
Blankets	
Tape	
Special Tools	Notes
Installation Tools	Notes
Clip Removal Tool	Panel Pry Tool # 1
Screw Driver	Phillips #2, Small Flat
Ratchet	3/8" Drive, 1/2" Drive
1/2" Drive Sockets	17mm, 18mm
3/8" Drive Sockets	10mm, 12mm, 13mm, 14mm, 18mm
Medium Extension Wrench	3/8" Drive, 1/2" Drive
18mm Torque Wrench	3/8" Drive, 1/2" Drive
Exhaust Hanger Removal Tool	
Scraper	
Scissors or Knife	
Tin Snips	
Hack Saw	
Special Chemicals	Notes

Legend

 **STOP:** Damage to the vehicle may occur. Do not proceed until process has been complied with.



 **OPERATOR SAFETY:** Use caution to avoid risk of injury.

 **CAUTION:** A process that must be carefully observed in order to reduce the risk of damage to the accessory/vehicle and to ensure a quality installation.

 **TOOLS & EQUIPMENT:** Used in Figures calls out the specific tools and equipment recommended for this process.

 **REVISION MARK:** This mark highlights a change in installation with respect to previous issue.

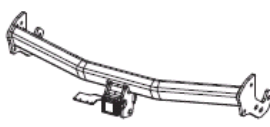
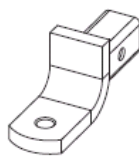
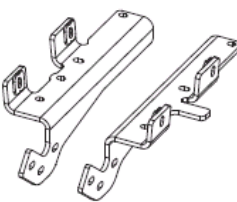
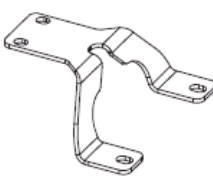
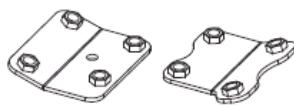
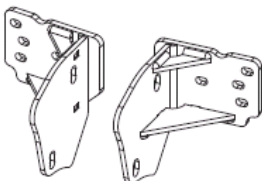
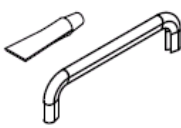
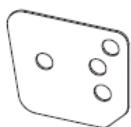
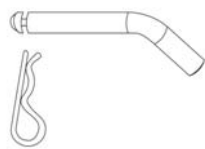
 **SAFETY TORQUE:** This mark indicates that torque is related to safety.

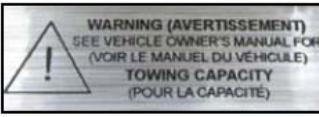
 <p>TOW BAR WELDED ASSEMBLY (Item 1)</p>	 <p>TONGUE (Item 2)</p>
 <p>LH & RH SIDE ARM ASSEMBLY (Item 3-4)</p>	 <p>BODY BRACE (Item 5)</p>
 <p>LH & RH REINFORCEMENT PLATE (Item 6-7)</p>	 <p>LH & RH REAR BRACKET ASSEMBLY (Item 8-9)</p>
 <p>BUMPER COVER TRIM & SUPER GLUE (Item 10)</p>	 <p>SHIM PLATE (Item 11)</p>
 <p>PIN & CLIP (Item 12)</p>	 <p>FASTENERS (Item 13-19)</p>
 <p>HITCH PLUG (Item 20)</p>	 <p>WARNING LABEL (Item 21)</p>

Care must be taken when installing this accessory to ensure damage does not occur to the vehicle. The installation of this accessory should follow approved guidelines to ensure a quality installation.

These guidelines can be found in the "Accessory Installation Practices" document.

This document covers such items as:-

- Vehicle Protection (use of covers and blankets, cleaning chemicals, etc.).
- Safety (eye protection, rechecking torque procedure, etc.).
- Vehicle Disassembly/Reassembly (panel removal, part storage, etc.).
- Electrical Component Disassembly/Reassembly (battery disconnection, connector removal, etc.).

Please see your Toyota dealer for a copy of this document.

1. Remove the Interior Parts.

- (a) Check the contents of the kit before starting.
- (b) Remove the tonneau cover and lift out the trunk floor panel (Fig. 1-1).

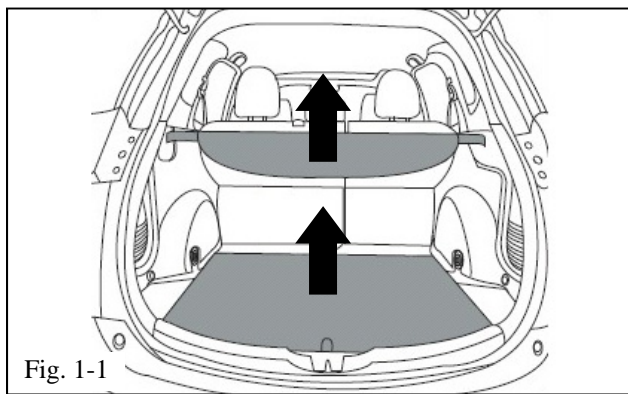

Fig. 1-1

- (c) Remove the three clips of the LH storage tub. Pull up to release the tub and retain the parts for reinstallation (Fig. 1-2).

⚠ NOTE: On hybrid vehicles, this step can only be done after Step 1(f).

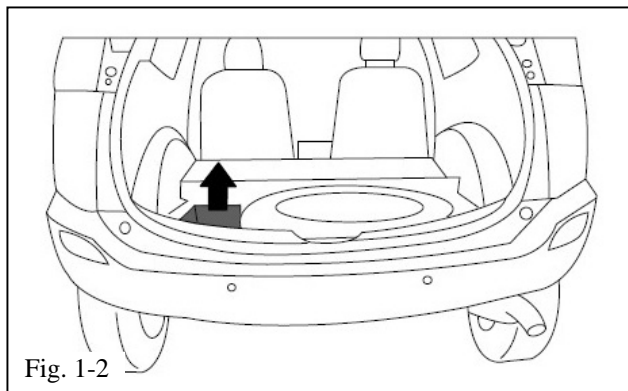

Fig. 1-2

- (d) Pull up to release and remove the rear scuff panel (Fig. 1-3).
- (e) Remove the four Phillips head screws, then pull up to release the rear intermediate cover and remove it (Fig. 1-3). Retain the parts for reassembly.

⚠ NOTE: On hybrid vehicles, remove the seven clips that attach to the rear seats.

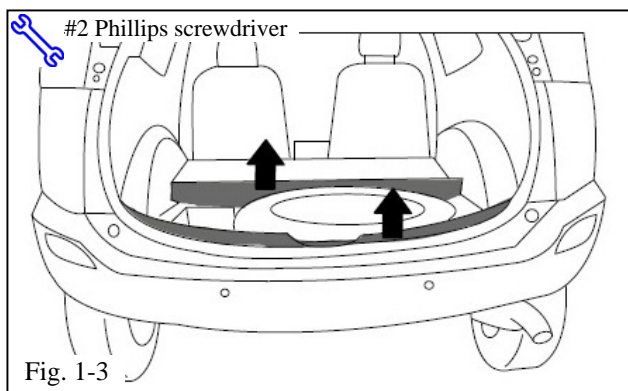
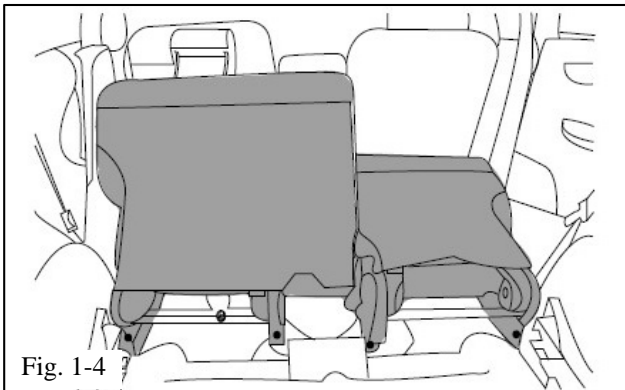
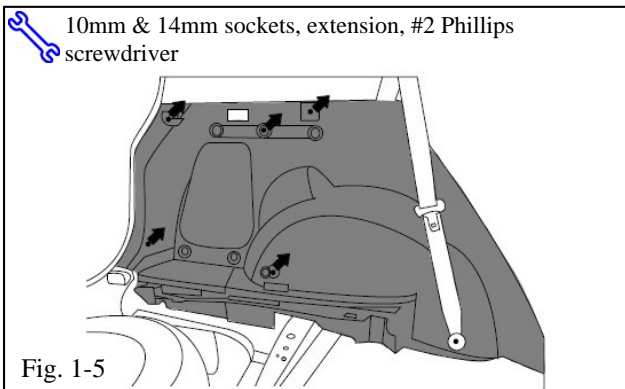

Fig. 1-3



- (f) Fold the rear seats forward to give access to the interior trim panels. (Fig. 1-4).

⚠ NOTE: DO NOT REMOVE THE SEATS.



- (g) Remove the interior trim.

- (1) Remove the cargo tie-down bolt, the three small mount bolts & the Phillips head screw to remove the LH rear interior trim panel (Fig. 1-5).
- (2) Lift the LH rear doorway scuff panel.
- (3) Pull the LH rear interior trim panel to release it and give access to the rear floor area for Step 3(g).
- (4) Disconnect the LH interior light plug.
- (5) Retain all parts for reinstallation.
- (6) Repeat on the RH side.

2. Remove the Exterior Parts.

- (a) Remove the LH mud flap.

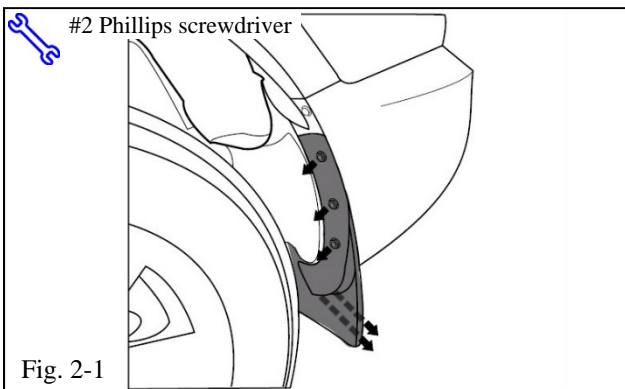

- (1) Remove the three screws in the wheel arch and the two screws underneath (Fig. 2-1).
- (2) Retain all parts for reinstallation.
- (3) Repeat on the RH side.

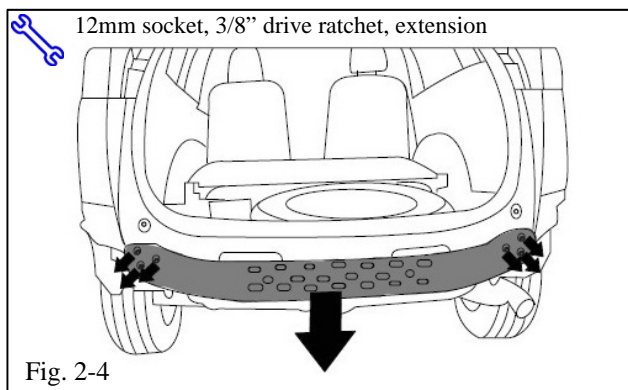
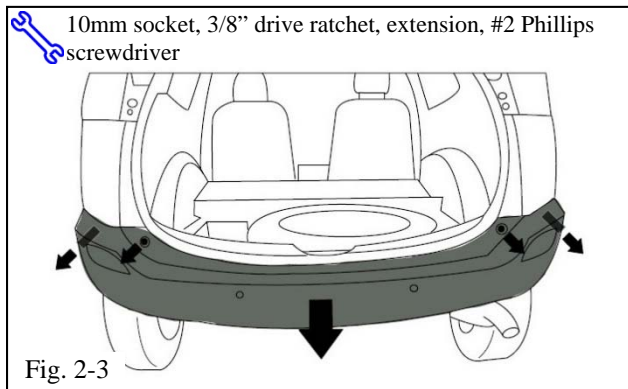
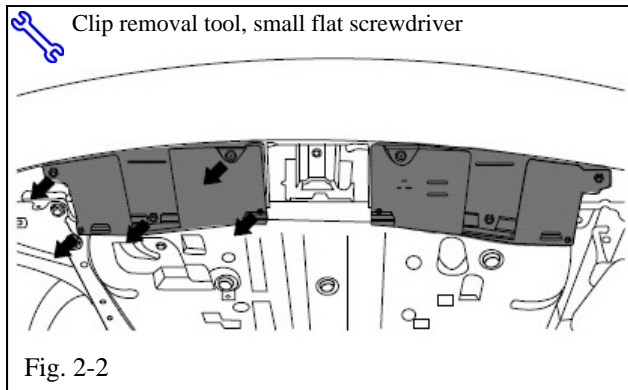

(b) Remove the LH rear under tray.

- (1) Remove the five clips (Fig. 2-2).
- (2) Retain all parts for reinstallation.
- (3) Repeat on the RH side.

(c) Remove the rear bumper cover.

- (1) Remove the screw in each wheel arch and the two screws on the rear face (Fig. 2-3).
- (2) Disconnect the rear park assist wiring loom plug in the LH rear inner corner (if equipped).
- (3) Pull the bumper cover sides outwards to release the ten claws (five per side).
- (4) Retain all parts for reinstallation.

(d) Remove the rear impact beam by removing the six bolts (Fig. 2-4). It will not be reused.

(e) Remove the six bolts (3 on each side) retaining the impact beam mounting LH/RH supports. They will not be reused.

(f) Remove the LH undercover.

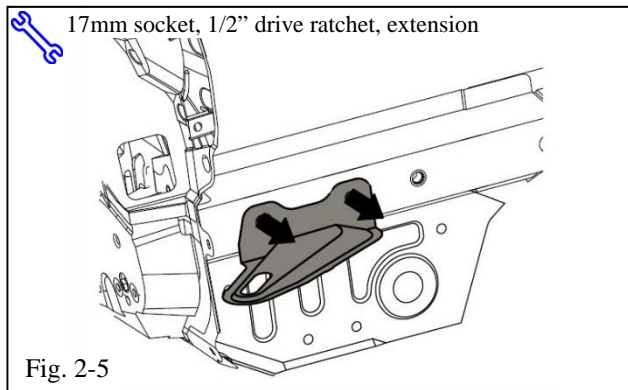

(g) Remove the two bolts and the tow hook from under the LH side chassis (Fig. 2-5). Retain the tow hook but discard the fasteners.

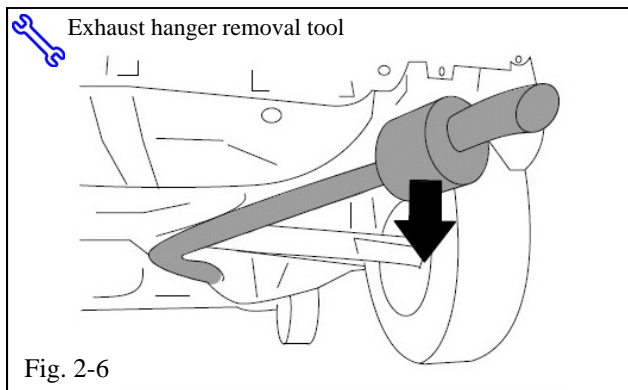

(h) Unhook the rubber hanger on the muffler and the rubber hanger behind the rear suspension cradle to release the muffler. Allow the muffler to hang loose (Fig. 2-6).

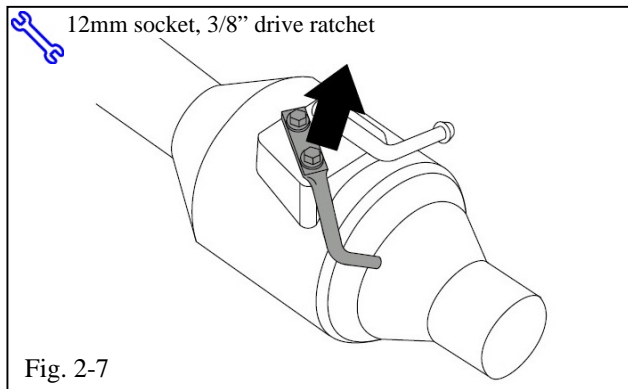

(i) Remove the two fasteners to remove the inner muffler bump stop (Fig. 2-7). Discard the bump stop and fasteners.

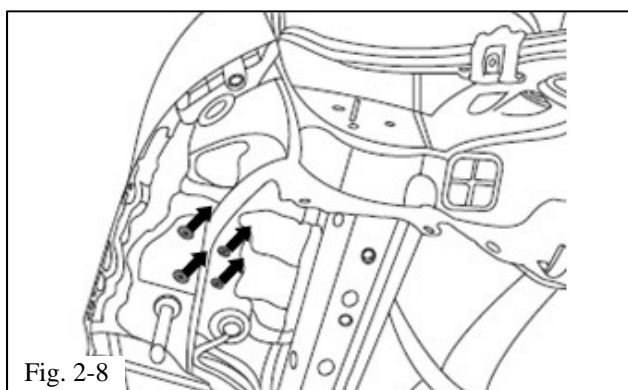

(j) Remove the four grommets from the LH rear floor and discard them (Fig. 2-8). Repeat on the RH side.

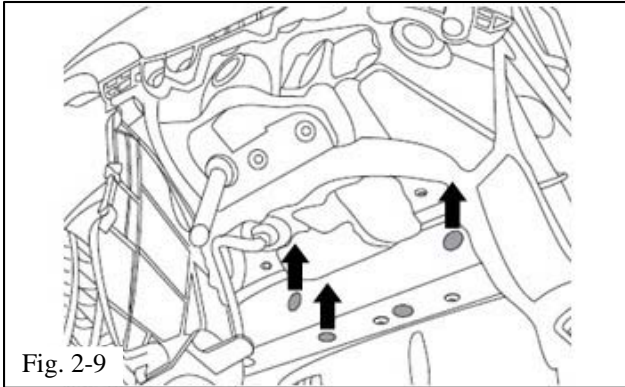

- (k) Remove the three hole plugs from the LH chassis rail and discard them (Fig. 2-9).

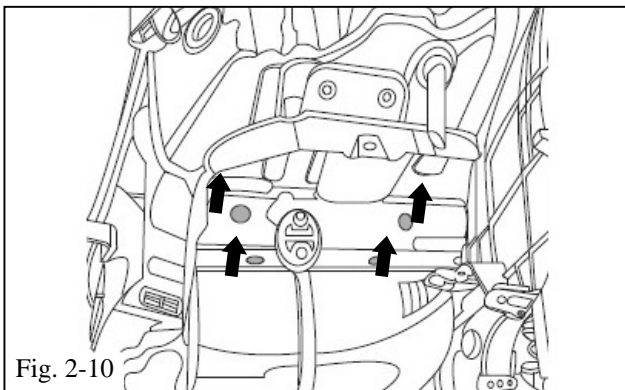

- (l) Remove the four hole plugs from the RH chassis rail and discard them (Fig. 2-10).

3. Install the Tow Hitch.

STOP NOTE: REMOVE AND DISCARD THE BOLT USED FOR SHIPPING (Fig. 3-1).

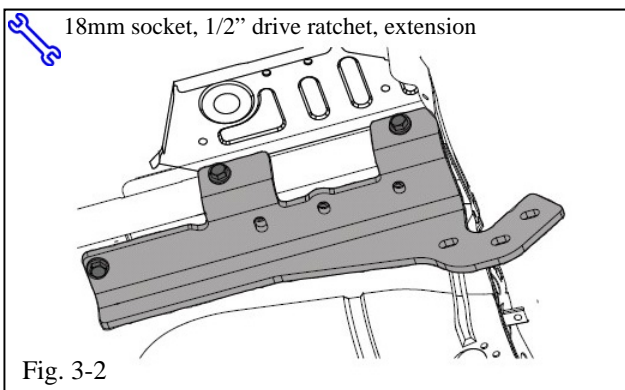

- (a) Use two M12 bolts and washers in the two horizontal positions and one M12 bolt and washer in the forward most vertical position to loosely secure the LH side arm (Item 3) to the chassis rail (Fig. 3-2).
- (b) Repeat for the RH side arm (Item 4).

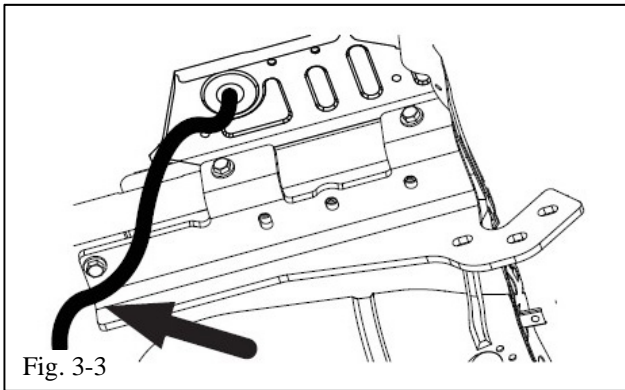

- (c) If the vehicle is equipped with self-leveling head lights, carefully reposition the sensor loom around the LH sidearm (Fig 3-3).

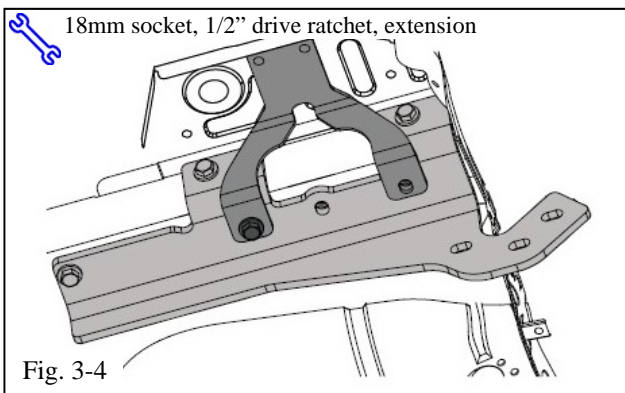

- (d) Use one M12 bolt and washer in the forward most vertical position to loosely secure the body brace (Item 5) over the LH sidearm (Item 3, Fig. 3-4).

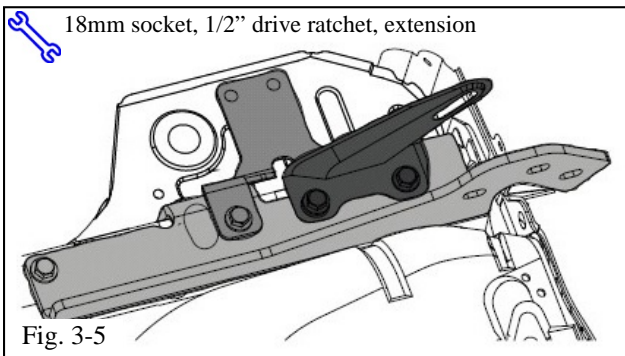

- (e) Reinstall the tow hook on the LH chassis over the body brace (Item 5, Fig. 3-5).
 - (1) Use the M12 thick washer (Item 19) in the forward most mount point (between the tow hook and LH side arm) to accommodate the body brace material thickness.
 - (2) Use two M12 bolts and washers to mount the hook.

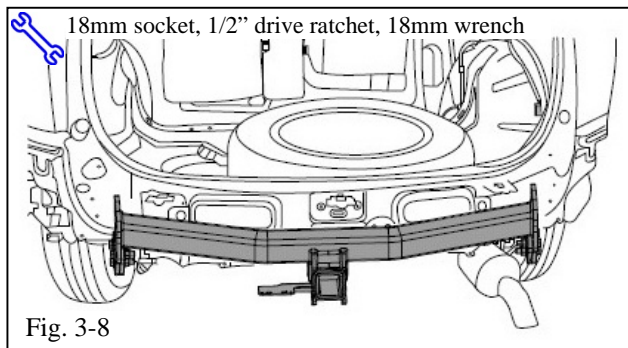
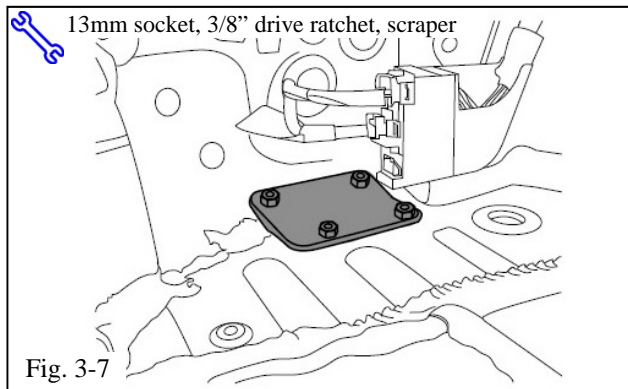
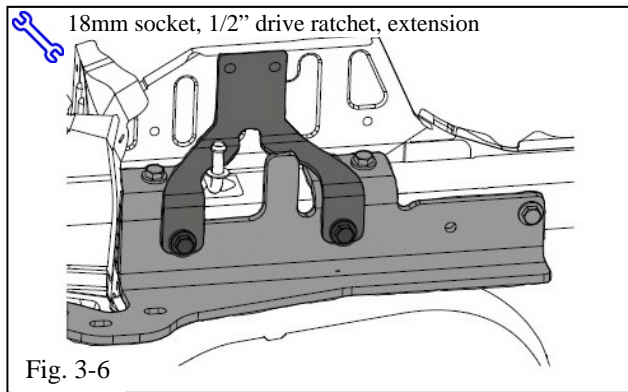

(f) Use two M12 bolts and washers to loosely secure the body brace (Item 5) over the RH sidearm (Item 4, Fig. 3-6).

(g) Gently pull the LH interior trim panel towards the center of vehicle to gain access behind it.

⚠ NOTE: Take care when pulling the interior trim panel to avoid damage.

(h) Use four M8 washers and M8 x 25 bolts (Items 17 & 18) to loosely secure the LH reinforcement plate (Item 6) inside the vehicle cabin (Fig. 3-7).

(i) Install the bolts and washers from the underside through the body brace (Item 5).

⚠ NOTE: Remove all excess sealant so that the reinforcement plates sit flat. Coat any bare metal with 3M Ultra Underbody Sealant - C0009-08302.

(j) Repeat Steps 1(h) & 1(i) for the RH reinforcement plate (Item 7).

(k) Use six M12 bolts, 12 M12 washers & six M12 nuts (Items 13, 14 & 15) to loosely secure the tow bar center section (Item 1) to the side arms (Items 3 & 4, Fig. 3-8).

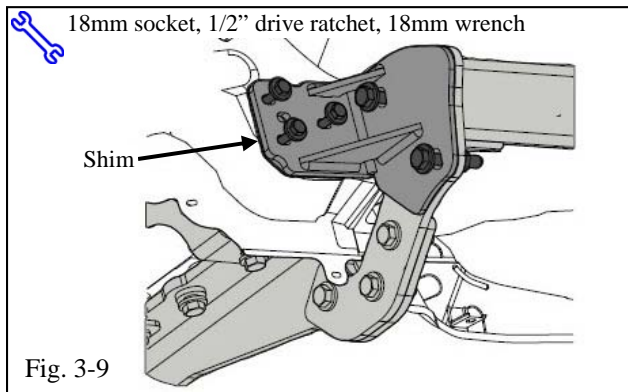

- (1) Loosely secure the LH rear bracket assembly (Item 8) and one shim plate (Item 11) between the tow bar center section (Item 1) and the rear panel (Fig. 3-9).

- (1) Fasten the LH rear bracket assembly and shim plate to the rear panel with three M8 x 35 bolts and washers (Items 16 & 17).

- (2) Fasten the LH rear bracket assembly to the tow bar center section (Item 1) with two M12 bolts, four M12 washers and two M12 nuts (Items 13, 14 & 15).

- (3) Repeat on the RH side.

- (m) Align the tow bar center section to the side arms and the center of the vehicle (Fig. 3-10). Torque the fasteners in the following sequence:

- (1) M12 center section horizontal to rear corner brackets (Fig. 3-10).



Torque: 92 N-m (68 ft-lbf)

- (2) M8 rear vertical corner brackets to the body (Fig. 3-11).



Torque: 25 N-m (18 ft-lbf)

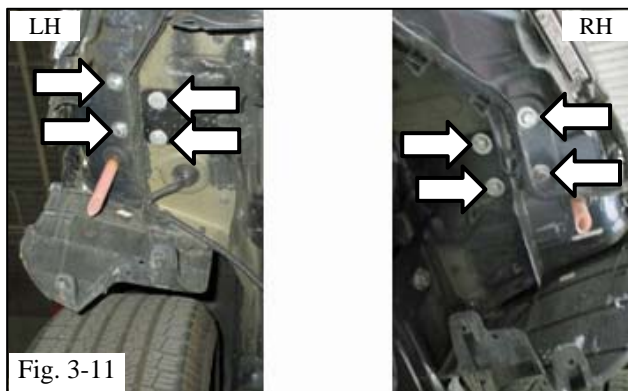
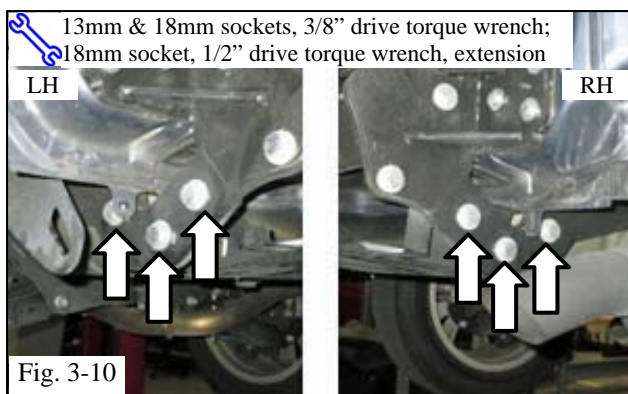

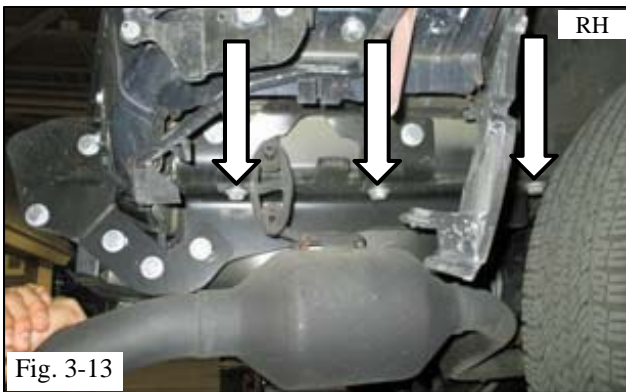
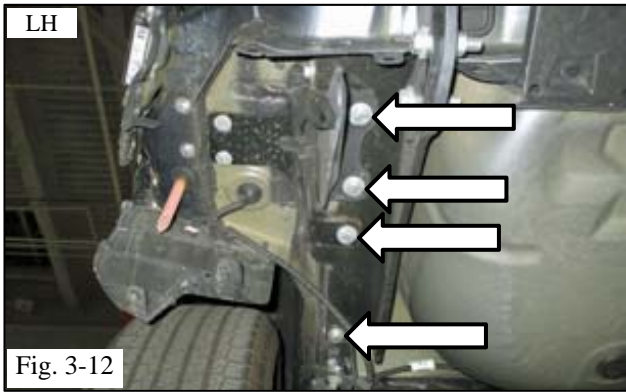

(3) M12 chassis vertical connections (Fig. 3-12 & Fig. 3-13).



Torque: 92 N-m (68 ft-lbf)

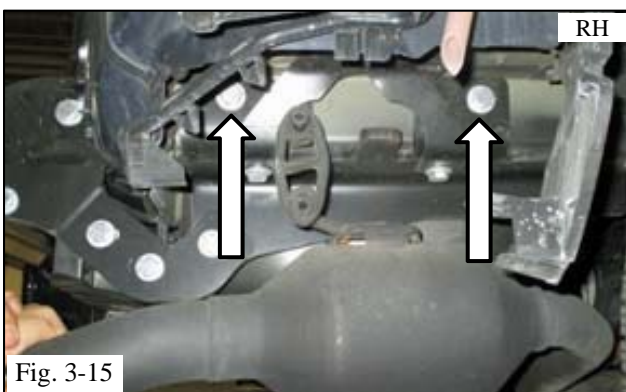
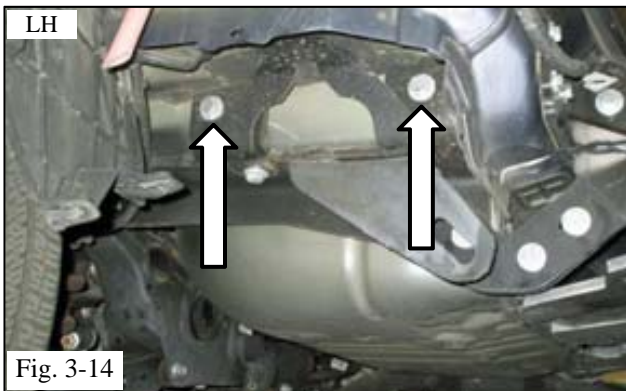

(4) M12 chassis horizontal connections (Fig. 3-14 & Fig. 3-15).



Torque: 92 N-m (68 ft-lbf)

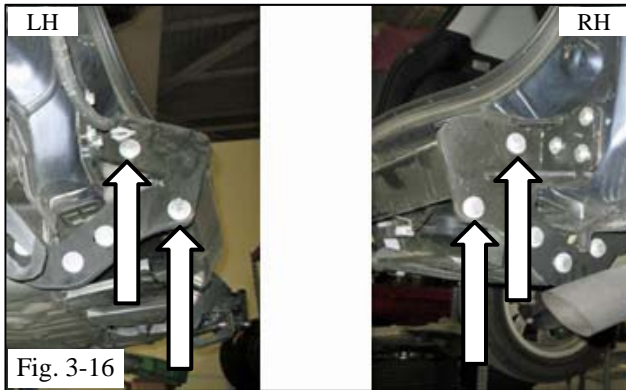

(5) M12 center section to the side arms (Fig. 3-16).



Torque: 9-2 Nm (68 ft-lbf)

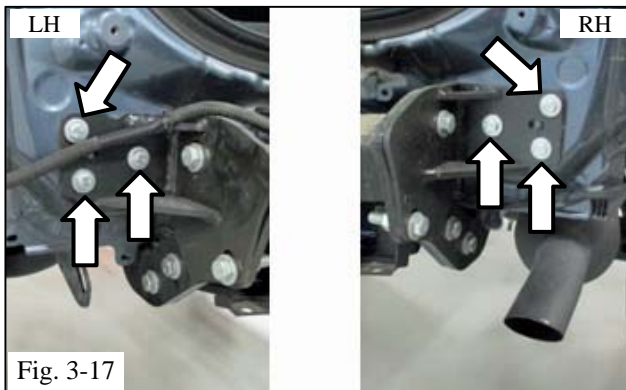

(6) M8 nut plates (Fig. 3-17).



Torque: 25 N-m (18 ft-lbf)



Re-torque all fasteners again, Steps 3(m)(1) through (6) above.

4. Modify the Bumper Cover.

- (a) Use the templates provided at the end of these instructions to drill corner locations and cut the middle and lower section of the rear bumper cover.



NOTE: Ensure that all dimensions of the templates are to scale before proceeding.

- (b) Cut the lower edge of the templates using scissors.



(c) Generously apply tape to the anticipated cutting area on the bumper cover to protect it from damage (Fig. 4-1).

- (d) Position the template on the outside of the bumper cover.



NOTE: Apply additional tape to the main cutting edges of the template as a visual aid for cutting the bumper cover.

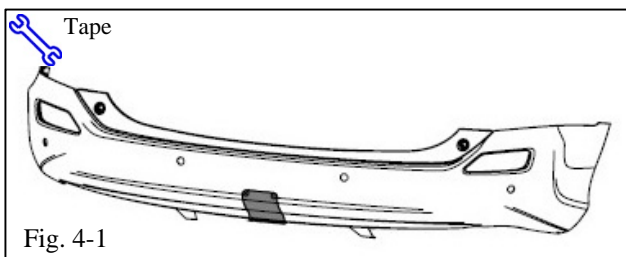

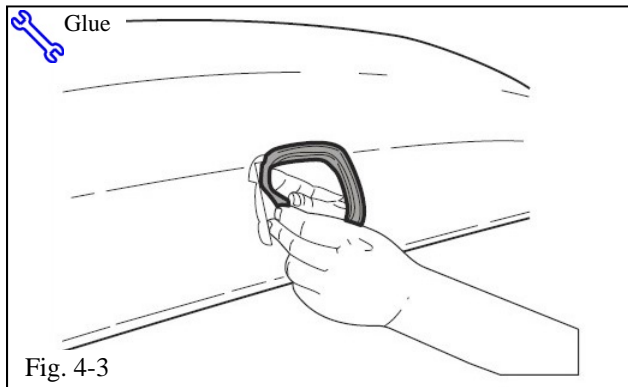
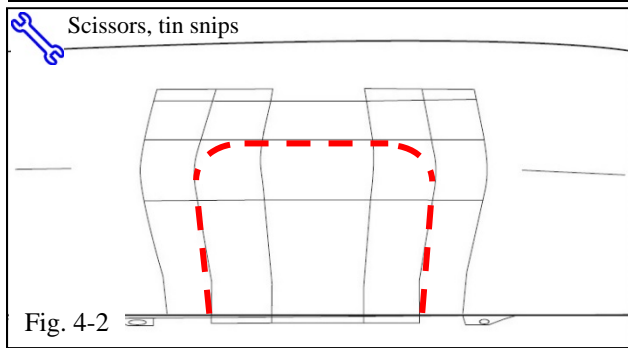

+ (e) Use tin snips to carefully cut along the DOTTED LINES marked on the template (Fig. 4-2).

! **NOTE:** Take care to cut safely and neatly along the dotted lines marked on the template.

(f) Carefully remove the templates and tape from the bumper cover.

(g) Fit the bumper cover trim (Item 10a) to the cut-out and work it into position.

(h) Lift the inside edge of the bumper cover trim and apply glue (Item 10b) evenly around the length of the bumper cover trim (Fig. 4-3).

! **NOTE:** Do not use an excessive amount of glue. Prevent glue from running into the visible area of the bumper cover.

! **NOTE:** Use masking tape to secure the bumper cover trim in place until the glue has set, then remove the masking tape and cut off any excess bumper cover trim material.

STOP **NOTE:** If the trailer wire harness will be installed, refer to the trailer wire harness instructions for wire routing prior to reinstalling the rear bumper cover.

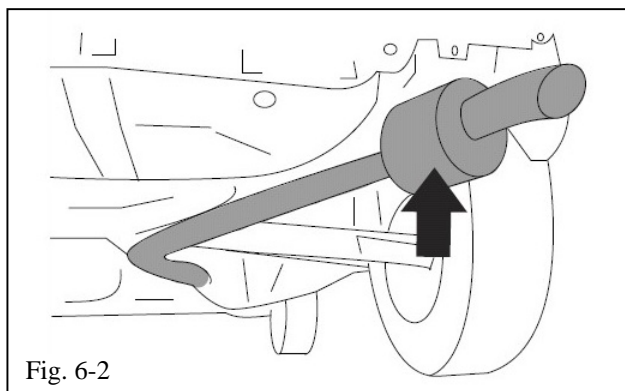
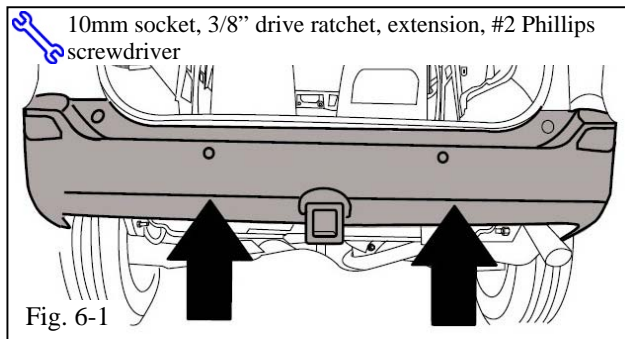
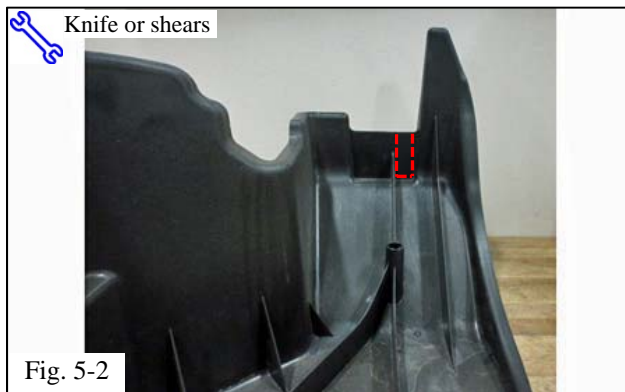

5. Modify the LH Undercover.

(a) Cut undercover using hack saw or equivalent (Fig. 5-1).

(b) Use a knife or shears to cut the undercover (Fig. 5-2).

6. Reinstall the Factory Parts.

(a) Reinstall the bumper cover (Fig. 6-1). See Step 2(c).
(b) Reinstall the LH and RH rear undertray. See Step 2(b).
(c) Reinstall the LH and RH mud flaps. See Step 2(a).

(d) Refit the muffler (Fig. 6-2). See Step 2(g).

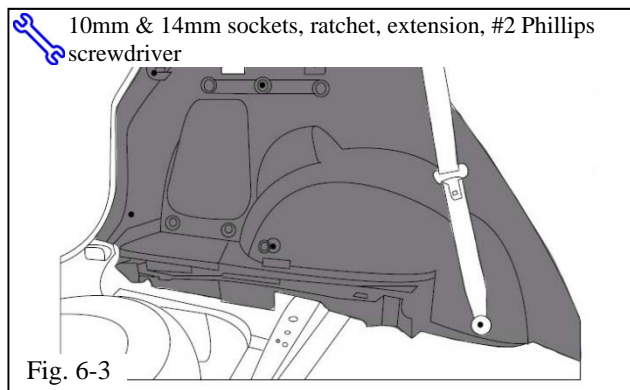

- (e) Refit the LH and RH rear interior trim panels (Fig. 6-3). See Step 1(f).

⚠ NOTE: Ensure the rear interior light plug is reconnected.

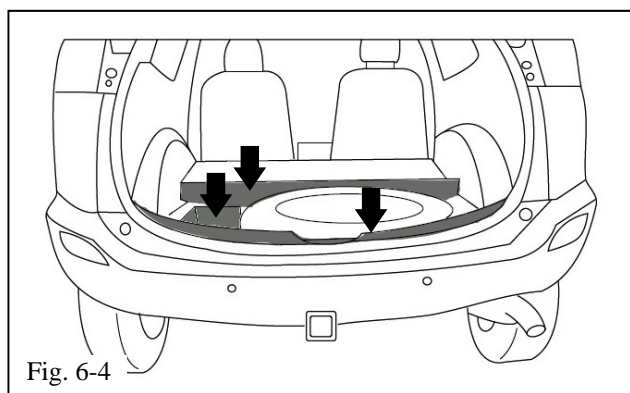

- (f) Reinstall the rear intermediate cover, rear scuff panel and LH storage tub (Fig. 6-4). See Steps 1(b) through 1(d).

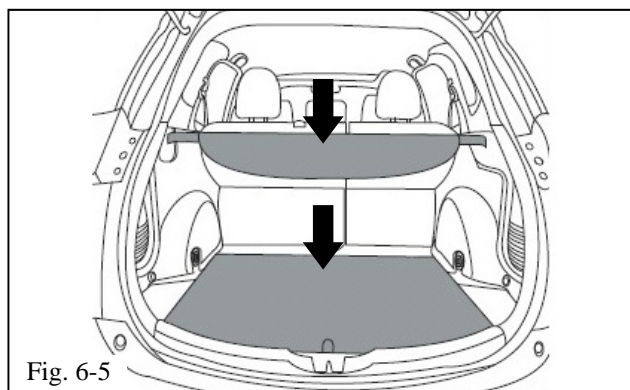

- (g) Reinstall the trunk floor panel and the tonneau cover (Fig. 6-5). See Step 1(a).

7. Install the Sticker and Store the Parts.

- (a) Use the alcohol preparation pads to wipe off any dirt, water or oil from the hitch bracket surface (Fig. 7-1).

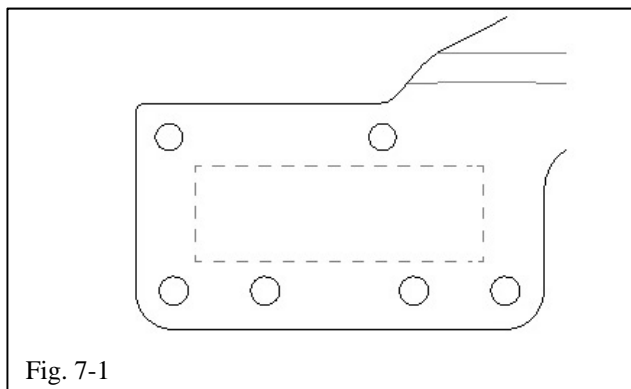

- (b) Peel the protective backing from the provided warning label (Item 21) and apply it to the hitch bracket in the location marked in Fig. 7-2.
- (c) Store the hitch plug (Item 20) in the glove box.
- (d) Store the tongue (Item 2) in a secure location within the vehicle.

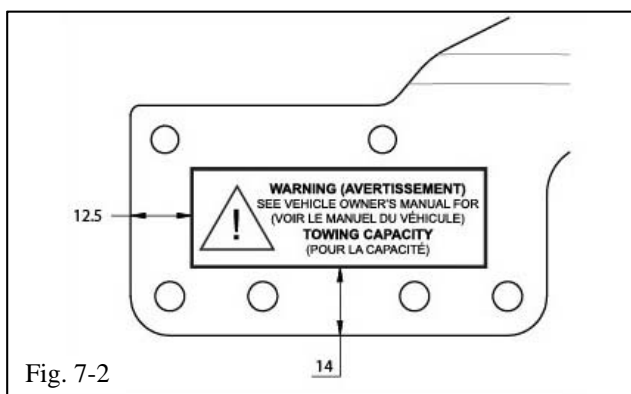

Checklist - these points **MUST** be checked to ensure a quality installation.

<u>Check:</u>	<u>Look For:</u>
<p><u>Accessory Function Checks</u></p> <p><input type="checkbox"/> Bolt Torques</p> <p><input type="checkbox"/> Hitch Plug</p> <p><input type="checkbox"/> Hitch Tongue</p>	<p>M12 center section to rear corner brackets – 92 N-m (68 ft-lbf)</p> <p>M8 rear corner brackets to the body – 25 N-m (18 ft-lbf)</p> <p>M12 chassis vertical connections – 92 N-m (68 ft-lbf)</p> <p>M12 chassis horizontal connections – 92 N-m (68 ft-lbf)</p> <p>M12 center section to the side arms – 92 N-m (68 ft-lbf)</p> <p>M8 nut plates – 25 N-m (18 ft-lbf)</p> <p>Verify the hitch plug is in the glove box.</p> <p> The tongue should be removed and stored when not towing.</p>
<p><u>Vehicle Function Checks</u></p> <p><input type="checkbox"/></p> <p><input type="checkbox"/></p> <p><input type="checkbox"/></p>	
<p><u>Vehicle Appearance Check</u></p> <p><input type="checkbox"/> After accessory installation and removal of protective cover(s), perform a visual inspection.</p>	<p>Ensure no damage (including scuffs and scratches) was caused during the installation process. (For PPO installations, refer to TMS Accessory Quality Shipping Standard.)</p>

THIS PAGE IS
INTENTIONALLY LEFT
BLANK



APPLICABLE FOR MIDDLE PORTION OF BUMPER

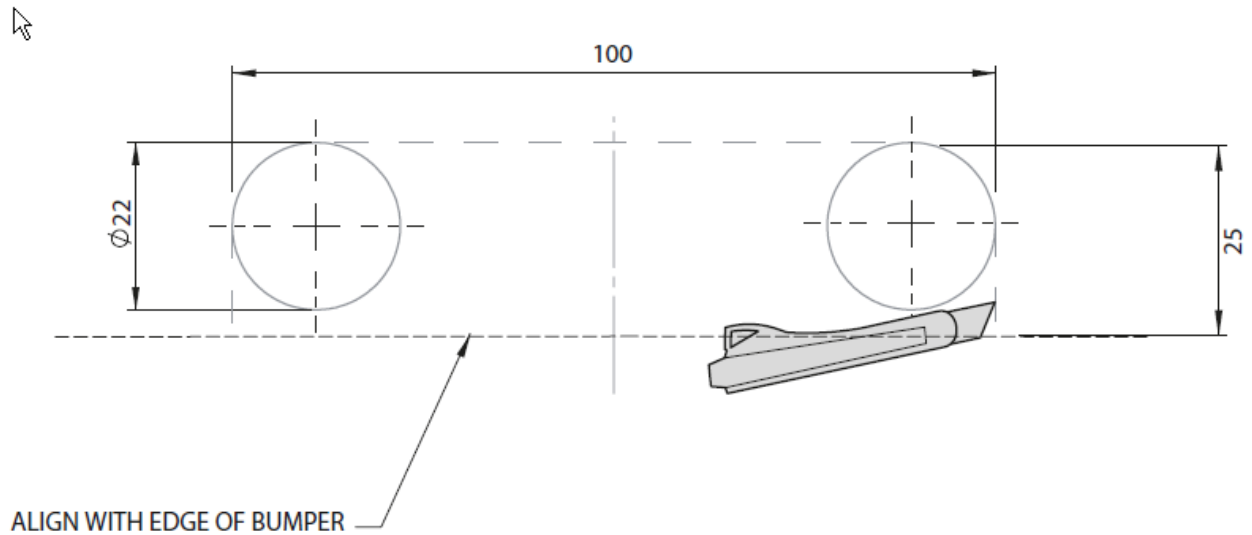

Ensure that all dimensions of the template are to scale before proceeding.

1. Cut the lower edge of the template using scissors.
2. Generously apply tape to the anticipated cutting area on the bumper cover to protect it from damage.
3. Position the template on the outside of the bumper cover.
4. Align the edge of the template with the lowest edge on the bumper cover and tape the template to the bumper cover.
5. Use tin snips to carefully cut along the **DOTTED LINES** marked on the template.
6. Carefully remove the template and tape from the bumper cover.



NOTE: Take care to cut safely and neatly along the dotted lines marked on the template.



APPLICABLE FOR LOWER PORTION OF BUMPER

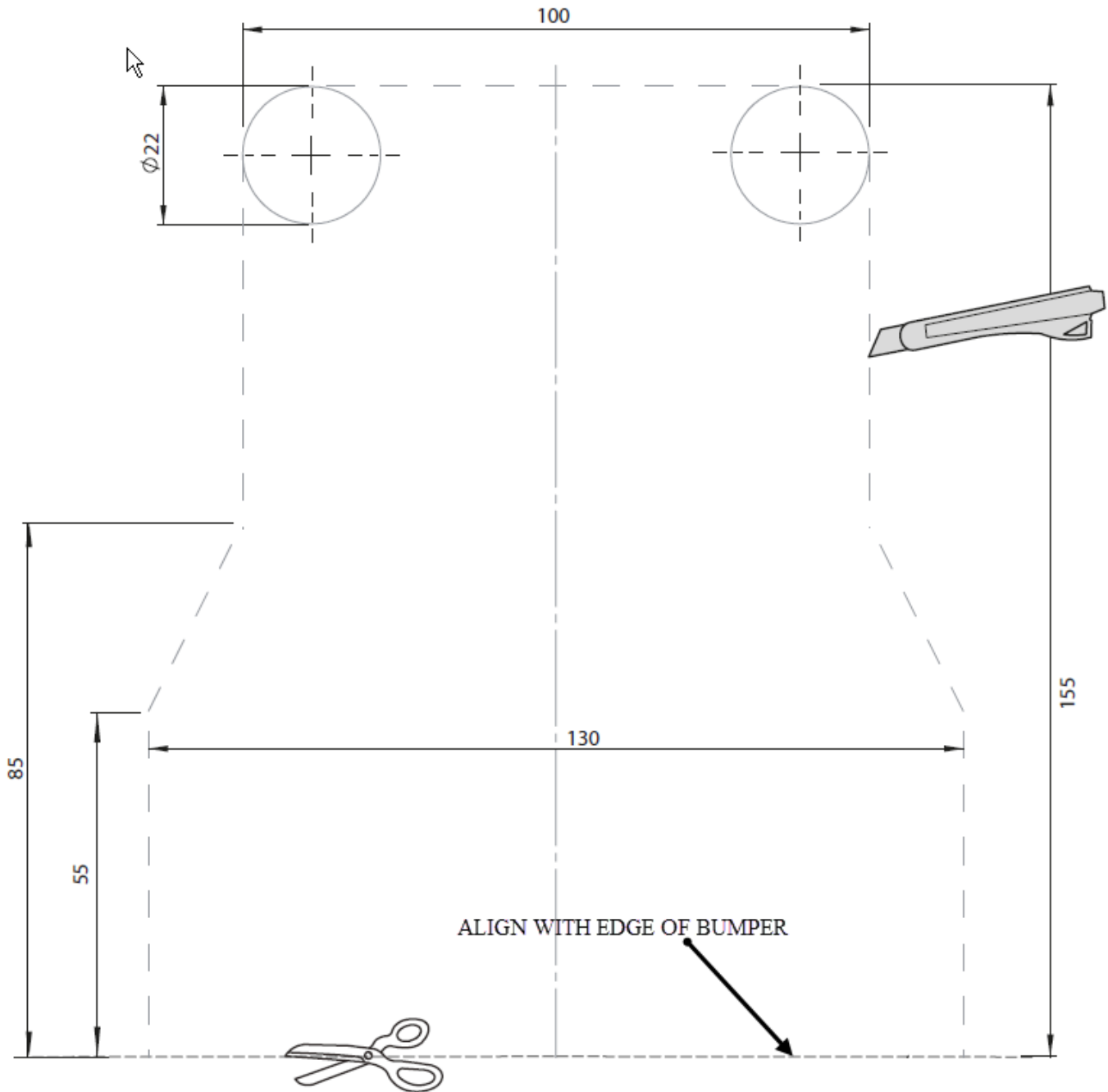

Ensure that all dimensions of the template are to scale before proceeding.

7. Cut the lower edge of the template using scissors.
8. Generously apply tape to the anticipated cutting area on the bumper cover to protect it from damage.
9. Position the template on the outside of the bumper cover.
10. Align the edge of the template with the lowest edge on the bumper cover and tape the template to the bumper cover.
11. Use tin snips to carefully cut along the **DOTTED LINES** marked on the template.
12. Carefully remove the template and tape from the bumper cover.



NOTE: Take care to cut safely and neatly along the dotted lines marked on the template.